

9920 and 9930 Cotton Picker

For complete service information also see:

6359 Engine	CTM4
6059 Engine	CTM8
Starting Motors and Alternators	CTM77
Radial Piston Pump	CTM7

John Deere Des Moines Works
TM1283 (29APR94)

LITHO IN U.S.A.
ENGLISH

INTRODUCTION

FOREWORD

This manual is written for an experienced technician. Essential tools required in performing certain service work are identified in this manual and are recommended for use.

Live with safety: Read the safety messages in the introduction of this manual and the cautions presented throughout the text of the manual.



This is the safety-alert symbol. When you see this symbol on the machine or in this manual, be alert to the potential for personal injury.

Technical manuals are divided in two parts: repair and diagnostics. Repair sections tell how to repair the components. Diagnostic sections help you identify the majority of routine failures quickly.

Information is organized in groups for the various components requiring service instruction. At the beginning of each group are summary listings of all applicable essential tools, service equipment and tools, other materials needed to do the job, service parts kits, specifications, wear tolerances, and torque values.

Binders, binder labels, and tab sets can be ordered by John Deere dealers direct from the John Deere Distribution Service Center.

This manual is part of a total product support program.

FOS MANUALS—REFERENCE

TECHNICAL MANUALS—MACHINE SERVICE

COMPONENT MANUALS—COMPONENT SERVICE

Fundamentals of Service (FOS) Manuals cover basic theory of operation, fundamentals of troubleshooting, general maintenance, and basic type of failures and their causes. FOS Manuals are for training new personnel and for reference by experienced technicians.

Technical Manuals are concise guides for specific machines. Technical manuals are on-the-job guides containing only the vital information needed for diagnosis, analysis, testing, and repair.

Component Technical Manuals are concise service guides for specific components. Component technical manuals are written as stand-alone manuals covering multiple machine applications.

HANDLE FLUIDS SAFELY—AVOID FIRES

When you work around fuel, do not smoke or work near heaters or other fire hazards.

Store flammable fluids away from fire hazards. Do not incinerate or puncture pressurized containers.

Make sure machine is clean of trash, grease, and debris.

Do not store oily rags; they can ignite and burn spontaneously.



DX,FLAME -19-04JUN90

10-05-1
-JUN-23AUG88
TS227

PREVENT BATTERY EXPLOSIONS

Keep sparks, lighted matches, and open flame away from the top of battery. Battery gas can explode.

Never check battery charge by placing a metal object across the posts. Use a volt-meter or hydrometer.

Do not charge a frozen battery; it may explode. Warm battery to 16°C (60°F).



DX,SPARKS -19-03MAR93

-JUN-23AUG88
TS204

PREPARE FOR EMERGENCIES

Be prepared if a fire starts.

Keep a first aid kit and fire extinguisher handy.

Keep emergency numbers for doctors, ambulance service, hospital, and fire department near your telephone.

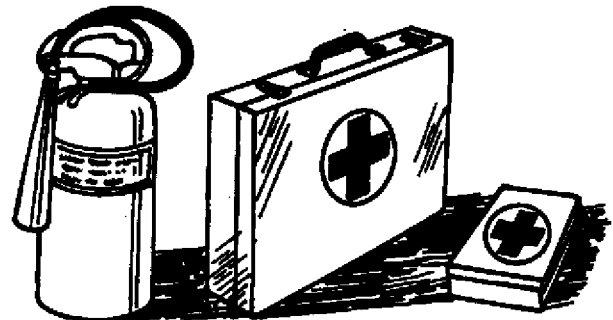

DX,FIRE2 -19-03MAR93

-JUN-23AUG88
TS291

PREVENT ACID BURNS

Sulfuric acid in battery electrolyte is poisonous. It is strong enough to burn skin, eat holes in clothing, and cause blindness if splashed into eyes.

Avoid the hazard by:

1. Filling batteries in a well-ventilated area.
2. Wearing eye protection and rubber gloves.
3. Avoiding breathing fumes when electrolyte is added.
4. Avoiding spilling or dripping electrolyte.
5. Use proper jump start procedure.

If you spill acid on yourself:

1. Flush your skin with water.
2. Apply baking soda or lime to help neutralize the acid.
3. Flush your eyes with water for 15—30 minutes. Get medical attention immediately.

If acid is swallowed:

1. Do not induce vomiting.
2. Drink large amounts of water or milk, but do not exceed 2 L (2 quarts).
3. Get medical attention immediately.

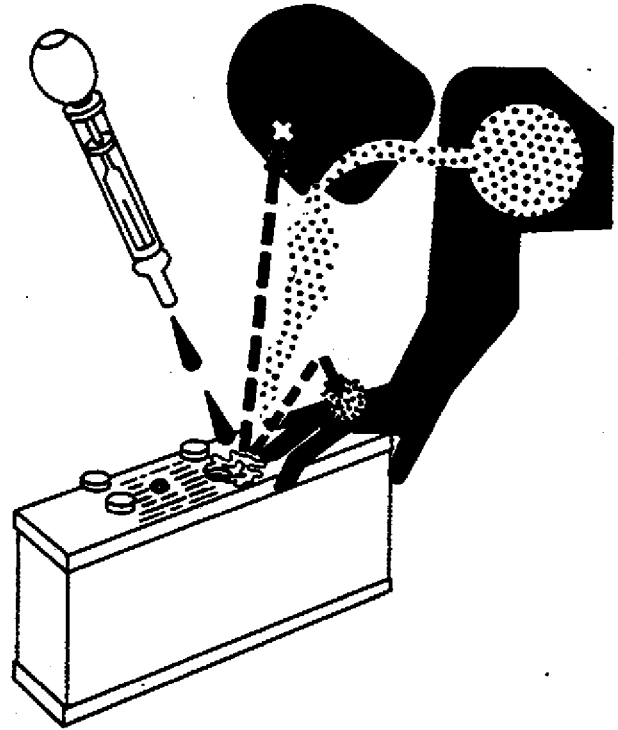

TS203 -JUN-23AUG88

DX,POISON -19-21APR93

HANDLE CHEMICAL PRODUCTS SAFELY

Direct exposure to hazardous chemicals can cause serious injury. Potentially hazardous chemicals used with John Deere equipment include such items as lubricants, coolants, paints, and adhesives.

A Material Safety Data Sheet (MSDS) provides specific details on chemical products: physical and health hazards, safety procedures, and emergency response techniques.

Check the MSDS before you start any job using a hazardous chemical. That way you will know exactly what the risks are and how to do the job safely. Then follow procedures and recommended equipment.

(See your John Deere dealer for MSDS's on chemical products used with John Deere equipment.)

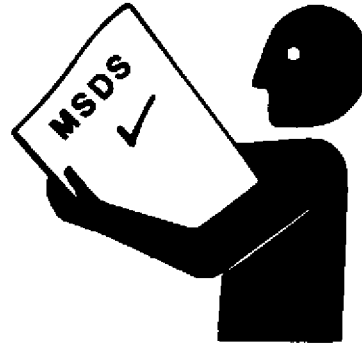

DX,MSDS,NA -19-03MAR93

10
3
5
-JUN-26NOV90
TS1132

AVOID HIGH-PRESSURE FLUIDS

Escaping fluid under pressure can penetrate the skin causing serious injury.

Avoid the hazard by relieving pressure before disconnecting hydraulic or other lines. Tighten all connections before applying pressure.

Search for leaks with a piece of cardboard. Protect hands and body from high pressure fluids.

If an accident occurs, see a doctor immediately. Any fluid injected into the skin must be surgically removed within a few hours or gangrene may result. Doctors unfamiliar with this type of injury should reference a knowledgeable medical source. Such information is available from Deere & Company Medical Department in Moline, Illinois, U.S.A.

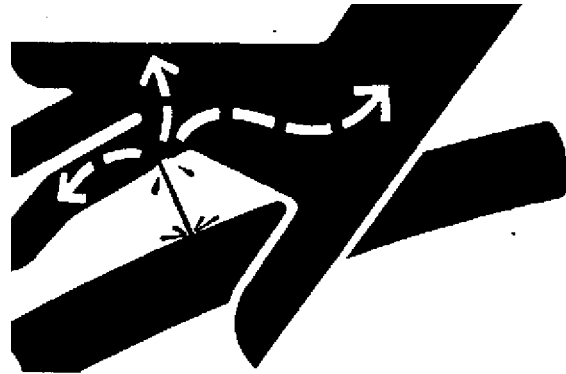

DX,FLUID -19-03MAR93

-JUN-23AUG88
X9811

10
05
4

AVOID CONTACT WITH ENGAGED PICKING UNIT

If service is required with engaged picking units, avoid contact with moving parts. Moving parts can puncture or dismember body parts, or cause death.

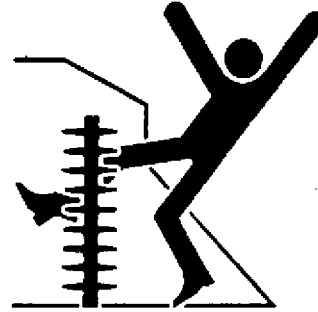

NX,N01,1000K -19-01DEC88

N39613 -JUN07OCT88

PARK MACHINE SAFELY

Before working on the machine:

- Lower all equipment to the ground.
- Stop the engine and remove the key.
- Disconnect the battery ground strap.
- Hang a "DO NOT OPERATE" tag in operator station.

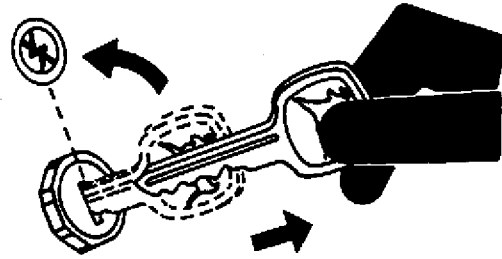

DX,PARK -19-04JUN90

TS230 -JUN24MAY89

- Look overhead for electric lines or low ceiling.

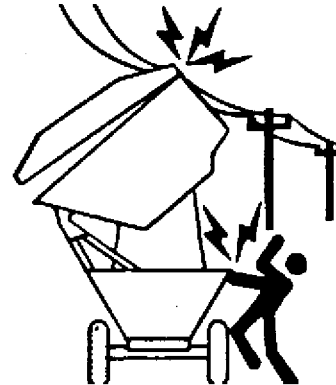

NX,N01,1000,L -19-01DEC88

N39671 -JUN30NOV88

SUPPORT MACHINE PROPERLY

Always lower the attachment or implement to the ground before you work on the machine. If you must work on a lifted machine or attachment, securely support the machine or attachment.

Do not support the machine on cinder blocks, hollow tiles, or props that may crumble under continuous load. Do not work under a machine that is supported solely by a jack. Follow recommended procedures in this manual.

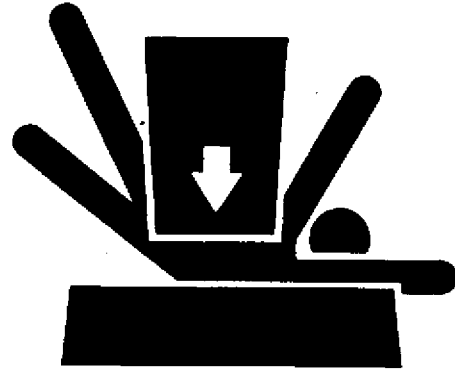

DX,LOWER -19-04JUN90

51910
-JUN-23AUG88
TS229

WEAR PROTECTIVE CLOTHING

Wear close fitting clothing and safety equipment appropriate to the job.

Prolonged exposure to loud noise can cause impairment or loss of hearing.

Wear a suitable hearing protective device such as earmuffs or earplugs to protect against objectionable or uncomfortable loud noises.

Operating equipment safely requires the full attention of the operator. Do not wear radio or music headphones while operating machine.

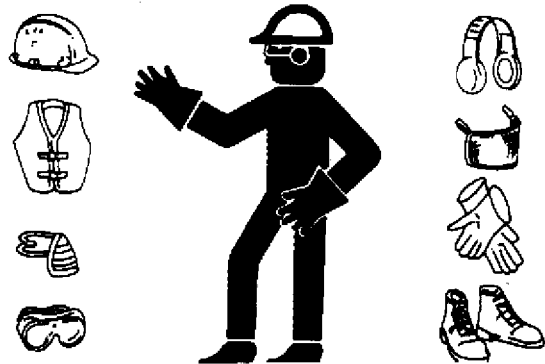

DX,WEAR -19-10SEP90

-JUN-23AUG88
TS206

WORK IN CLEAN AREA

Before starting a job:

- Clean work area and machine.
- Make sure you have all necessary tools to do your job.
- Have the right parts on hand.
- Read all instructions thoroughly; do not attempt shortcuts.

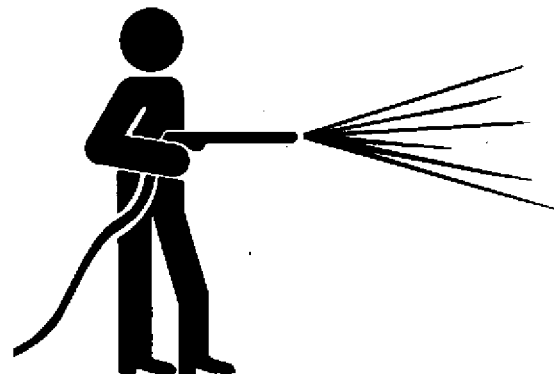

DX,CLEAN -19-04JUN90

-JUN-18OCT88
T6642EJ

10
05
6

SERVICE MACHINES SAFELY

Tie long hair behind your head. Do not wear a necktie, scarf, loose clothing, or necklace when you work near machine tools or moving parts. If these items were to get caught, severe injury could result.

Remove rings and other jewelry to prevent electrical shorts and entanglement in moving parts.

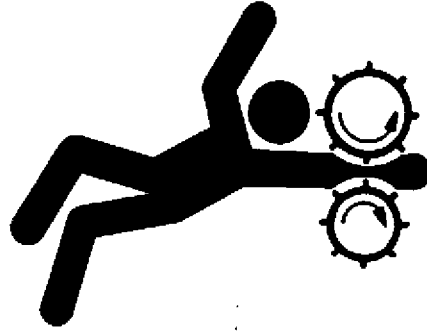

DX, LOOSE -19-04JUN90

TS228 -JUN-23AUG88

WORK IN VENTILATED AREA

Engine exhaust fumes can cause sickness or death. If it is necessary to run an engine in an enclosed area, remove the exhaust fumes from the area with an exhaust pipe extension.

If you do not have an exhaust pipe extension, open the doors and get outside air into the area.

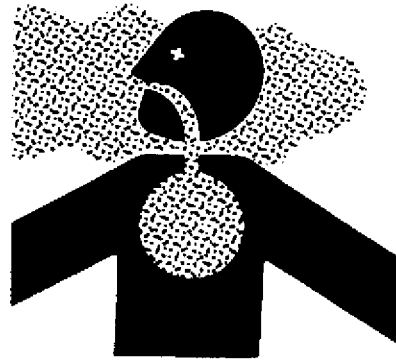

DX, AIR -19-04JUN90

TS220 -JUN-23AUG88

ILLUMINATE WORK AREA SAFELY

Illuminate your work area adequately but safely. Use a portable safety light for working inside or under the machine. Make sure the bulb is enclosed by a wire cage. The hot filament of an accidentally broken bulb can ignite spilled fuel or oil.



DX, LIGHT -19-04JUN90

TS223 -JUN-23AUG88

REPLACE SAFETY SIGNS

Replace missing or damaged safety signs. See the machine operator's manual for correct safety sign placement.

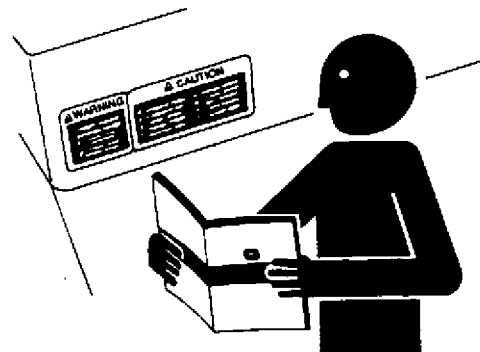

DX, SIGNS1 -19-04JUN90

TS201 -JUN-23AUG88

USE PROPER LIFTING EQUIPMENT

Lifting heavy components incorrectly can cause severe injury or machine damage.

Follow recommended procedure for removal and installation of components in the manual.

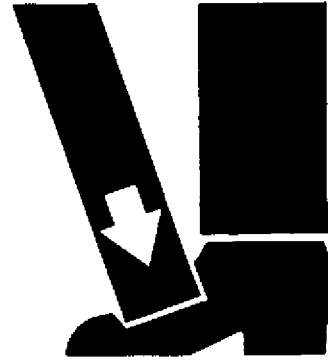

DX,LIFT -19-04JUN90

TS226 -JUN-23AUG88

10
95
7

REMOVE PAINT BEFORE WELDING OR HEATING

Avoid potentially toxic fumes and dust.

Hazardous fumes can be generated when paint is heated by welding, soldering, or using a torch.

Do all work outside or in a well ventilated area. Dispose of paint and solvent properly.

Remove paint before welding or heating:

- If you sand or grind paint, avoid breathing the dust. Wear an approved respirator.
- If you use solvent or paint stripper, remove stripper with soap and water before welding. Remove solvent or paint stripper containers and other flammable material from area. Allow fumes to disperse at least 15 minutes before welding or heating.

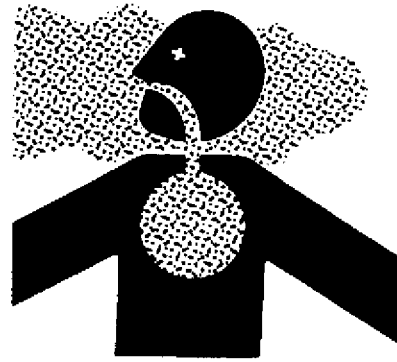

DX,PAINT -19-03MAR93

TS220 -JUN-23AUG88

AVOID HEATING NEAR PRESSURIZED FLUID LINES

Flammable spray can be generated by heating near pressurized fluid lines, resulting in severe burns to yourself and bystanders. Do not heat by welding, soldering, or using a torch near pressurized fluid lines or other flammable materials. Pressurized lines can be accidentally cut when heat goes beyond the immediate flame area.



DX,TORCH -19-03MAR93

TS953 -JUN-15MAY90

10
05
8

SERVICE TIRES SAFELY

Explosive separation of a tire and rim parts can cause serious injury or death.

Do not attempt to mount a tire unless you have the proper equipment and experience to perform the job.

Always maintain the correct tire pressure. Do not inflate the tires above the recommended pressure. Never weld or heat a wheel and tire assembly. The heat can cause an increase in air pressure resulting in a tire explosion. Welding can structurally weaken or deform the wheel.

When inflating tires, use a clip-on chuck and extension hose long enough to allow you to stand to one side and NOT in front of or over the tire assembly. Use a safety cage if available.

Check wheels for low pressure, cuts, bubbles, damaged rims or missing lug bolts and nuts.

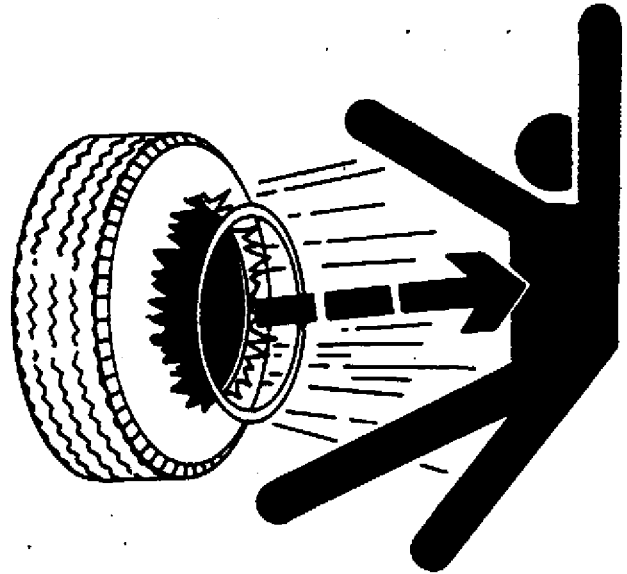

-JUN-23AUG88

TS211

DX,RIM -19-24AUG90

AVOID HARMFUL ASBESTOS DUST

Avoid breathing dust that may be generated when handling components containing asbestos fibers. Inhaled asbestos fibers may cause lung cancer.

Components in products that may contain asbestos fibers are brake pads, brake band and lining assemblies, clutch plates, and some gaskets. The asbestos used in these components is usually found in a resin or sealed in some way. Normal handling is not hazardous as long as airborne dust containing asbestos is not generated.

Avoid creating dust. Never use compressed air for cleaning. Avoid brushing or grinding material containing asbestos. When servicing, wear an approved respirator. A special vacuum cleaner is recommended to clean asbestos. If not available, apply a mist of oil or water on the material containing asbestos.

Keep bystanders away from the area.

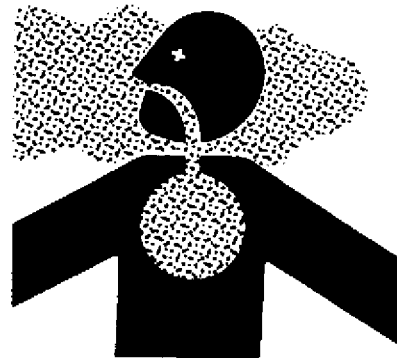

-JUN-23AUG88

TS220

DX,DUST -19-15MAR91

PRACTICE SAFE MAINTENANCE

Understand service procedure before doing work. Keep area clean and dry.

Never lubricate, service, or adjust machine while it is moving. Keep hands, feet, and clothing from power-driven parts. Disengage all power and operate controls to relieve pressure. Lower equipment to the ground. Stop the engine. Remove the key. Allow machine to cool.

Securely support any machine elements that must be raised for service work.

Keep all parts in good condition and properly installed. Fix damage immediately. Replace worn or broken parts. Remove any buildup of grease, oil, or debris.

Disconnect battery ground cable (-) before making adjustments on electrical systems or welding on machine.



-JUN-23AUG88

TS218

DX,SERV -19-03MAR93

USE PROPER TOOLS

Use tools appropriate to the work. Makeshift tools and procedures can create safety hazards.

Use power tools only to loosen threaded parts and fasteners.

For loosening and tightening hardware, use the correct size tools. DO NOT use U.S. measurement tools on metric fasteners. Avoid bodily injury caused by slipping wrenches.

Use only service parts meeting John Deere specifications.



-JUN-08NOV89

TS779

DX,REPAIR -19-04JUN90

10
05
10

DISPOSE OF WASTE PROPERLY

Improperly disposing of waste can threaten the environment and ecology. Potentially harmful waste used with John Deere equipment include such items as oil, fuel, coolant, brake fluid, filters, and batteries.

Use leakproof containers when draining fluids. Do not use food or beverage containers that may mislead someone into drinking from them.

Do not pour waste onto the ground, down a drain, or into any water source.

Air conditioning refrigerants escaping into the air can damage the Earth's atmosphere. Government regulations may require a certified air conditioning service center to recover and recycle used air conditioning refrigerants.

Inquire on the proper way to recycle or dispose of waste from your local environmental or recycling center, or from your John Deere dealer.

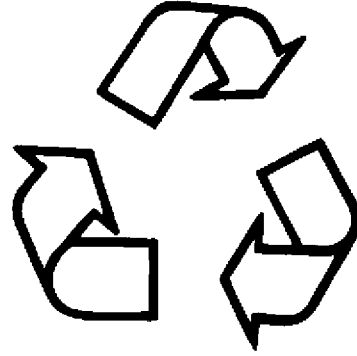

TS1133 -JUN-26NOV90

DX,DRAIN -19-03MAR93

LIVE WITH SAFETY

Before returning machine to customer, make sure machine is functioning properly, especially the safety systems. Install all guards and shields.



TS231 -19-07OCT88

DX,LIVE -19-25SEP92

9920 SPECIFICATIONS

ROW WIDTHS 914, 965, or 1016 mm (36, 38 or 40 inch)

PICKING UNITS

Number of units 2
 Number of picking drums 4
 Number of picker bars (per unit)
 Front drum 12
 Rear drum 12
 Number of spindles (per machine)
 Low drum (14 per bar) 672
 High drum (20 per bar) 960

PICKING UNIT SPEEDS

Picking unit drive shaft 0—1150 rpm*
 Picking drum 0—145 rpm*
 Doffer shaft 0—1755 rpm*
 Spindle 0—4020 rpm*

GROUND SPEEDS (FULL THROTTLE)

Forward
 1st gear 0—5.14 km/h (0—3.2 mph)
 2nd gear 0—6.05 km/h (0—3.8 mph)
 3rd gear 0—20.3 km/h (0—12.6 mph)
 4th gear 0—23.9 km/h (0—14.9 mph)

Reverse
 1st gear 0—2.6 km/h (0—1.6 mph)
 2nd gear 0—3.1 km/h (0—1.9 mph)
 3rd gear 0—10.1 km/h (0—6.3 mph)
 4th gear 0—12 km/h (0—7.45 mph)

CAPACITIES

Cotton basket 17.2 m³ (608 cu. ft)
 Fuel tank 261 L (69 U.S. gal)
 Water tank 553 L (146 U.S. gal)
 Cooling system 30.3 L (32 U.S. qt)
 Thermostat (each) two, 82°C (180°F)
 Engine crankcase, including filter 11.4 L (12 U.S. qt)
 Hydraulic system, including filter 19.9 L (21 U.S. qt)
 Hydraulic reservoir 17.4 L (18.4 U.S. qt)
 Transmission 22.7 L (24 U.S. qt)
 Hydrostatic drive 25.6 L (27 U.S. qt)
 Hydrostatic reservoir 17.4 L (18.4 U.S. qt)

* Speeds listed are theoretical maximums. Actual speeds will be approximately 5 percent lower due to slippage of hydrostatic transmission and drive belts.

10
10
2

TIRES

Front drive wheels 16.9 x 34 8PR (R1, R3) or 18.4 x 30 8PR (R2)
Rear guide wheel 11.00 x 16 8PR

TIRE INFLATION PRESSURE

Drive wheels 210 kPa (30 psi)
Guide wheels 252 kPa (36 psi)

HYDROSTATIC DRIVE

Make
Pump Eaton
Motor Eaton
Type of oil filter Full flow suction
Type of oil cooler Air-cooled

WEIGHT

Low drum 5811 kg (12,800 lb)
High drum 6084 kg (13,400 lb)

ELECTRICAL SYSTEM

Battery voltage 12-volt
Battery terminal grounded Negative
Battery
Group 31
Amps 625
Capacity (min.) 160
Alternator (S.N. 101-380) 72 Amp
(S.N. 381-) 90 Amp

ENGINE

Manufacturer John Deere
Model 6359 DN-01, Diesel
Number of cylinders 6
Bore 106.5 mm (4.19 in.)
Stroke 110 mm (4.33 in.)
Displacement 5883 cm³ (359 cu in.)
Horsepower 85 kW (114 hp)
Engine speeds
Fast idle (no load) 2640—2680 rpm
Rated (under field load) 2500 rpm
Slow idle 780—820 rpm
Muffler Aspirated

NX,N01,1005,AW -19-05FEB87

General Specifications/9920 Specifications

OPERATOR'S CAB

Type	Pressurized with heater, SOUND-GARD® (without ROPS) PERSONAL-POSTURE™ seat/deluxe suspension, windshield wiper, and rear view mirror
Optional attachment	Air conditioner
Windshield wiper	
Blade length	508 mm (20 in.)
Arm length	508 mm (20 in.)
Heater Capacity	5274 W (18,000 BTU)
Air conditioner	
Compressor make (S.N. 101-380)	Delco
(S.N. 381-)	Nippondenso
Capacity	6446 W (22,000 BTU)
Refrigerant	R-12
Refrigerant charge	Approx. 2 kg (4-1/2 lb)

NX,N01,1005,AX -19-05FEB87

10
10
3

10
10
4

9930 SPECIFICATIONS

PICKING UNITS

Number of units	2
Number of picking drums	4
Number of picker bars (per unit)	
Front drum	12
Rear drum	12
Number of spindles (per machine)	
Low drum (14 per bar)	672
High drum (20 per bar)	960
Row spacings	
Solid planting	914, 965, or 1016 mm (36, 38, or 40-in.)
Skip row	813 mm (32-in.)

PICKING UNIT SPEEDS (P.I.N. -10000)

Picking unit drive shaft	0—1130 rpm*
Picking drum	0—152 rpm*
Doffer shaft	0—1728 rpm*
Spindle	0—3885 rpm*

PICKING UNIT SPEEDS (P.I.N. 10001-)

Picking unit drive shaft	0—1138 rpm*
Picking drum	0—152 rpm*
Doffer shaft	0—1930 rpm*
Spindle	0—3915 rpm*

GROUND SPEEDS (FULL THROTTLE)

Forward	
1st gear	0—5.63 km/h (0—3.5 mph)
2nd gear	0—6.60 km/h (0—4.1 mph)
3rd gear	0—22.2 km/h (0—13.8 mph)
4th gear	0—26.2 km/h (0—16.3 mph)
Reverse	
1st gear	0—2.9 km/h (0—1.8 mph)
2nd gear	0—3.4 km/h (0—2.1 mph)
3rd gear	0—11.1 km/h (0—6.9 mph)
4th gear	0—13.1 km/h (0—8.15 mph)

* Speeds listed are theoretical maximums. Actual speeds will be approximately 5 percent lower due to slippage of hydrostatic transmission and drive belts.

NX1283,1005.A -19-09JUN93

CAPACITIES

Cotton basket	
Standard	17.2 m ³ (608 cu ft)
With 356 mm [14 in.] extension	20.4 m ³ (727 cu ft)
Fuel tank	261 L (69 U.S. gal)
Water/solution tank	643 L (170 U.S. gal)
Lubrication reservoir	227 L (60 U.S. gal)
Cooling system	32.2 L (34 U.S. qt)
Engine crankcase, includes filter	18.9 L (20.0 U.S. qt)
Hydraulic system, includes filter	19.9 L (21 U.S. qt)
Hydraulic reservoir	17.4 L (18.4 U.S. qt)
Transmission	23.6 L (25 U.S. qt)
Hydrostatic drive	25.6 L (27 U.S. qt)
Hydraulic reservoir	17.4 L (18.4 U.S. qt)
Final drive (each)	1.9 L (2 U.S. qt)

TIRES

Drive wheels	
Cleat, 16.9 x 34 10PR (R1)	221 kPa (2.0 bar) (32 psi)
Cane and Rice, 18.4 x 30 10PR (R2)	207 kPa (2.0 bar) (30 psi)
Low Profile, 16.9 x 34 10PR (R3) (P.I.N. -12000)	221 kPa (2.1 bar) (32 psi)
Single Guide Wheel, Rib, 11.00 x 16 8PR (F2M)	248 kPa (2.5 bar) (36 psi)
Dual Guide Wheels, Rib, 7.50 x 24 6PR (I1)	303 kPa (3.0 bar) (44 psi)

HYDROSTATIC DRIVE

Make	SUNDSTRAND
Type of oil filter	Full flow suction
Type of oil cooler	Air-cooled
Type of oil	John Deere HY-GARD® Hydraulic and Transmission Fluid

WEIGHT

Low drum	
Standard	6345 kg (13,975 lb)
With 356 mm [14 in.] extension and vane dump control less tire ballast	7091 kg (15,620 lb)
High drum	
Standard	6617 kg (14,575 lb)
With 356 mm [14 in.] extension and vane dump control less tire ballast	7364 kg (16,220 lb)

FINAL DRIVE

Type	Pinion and ring gear
------	----------------------

ELECTRICAL SYSTEM

Battery voltage	12-volt
Battery terminal grounded	Negative
Battery	
Group	31
Amps (P.I.N -14000)	625
(P.I.N. 14001-)	925
Capacity (min.) (P.I.N -14000)	160
(P.I.N. 14001-)	180
Alternator (P.I.N. -12000)	90 Amp
(P.I.N. 12001-)	95 Amp

10
10
6

ENGINE

Model (P.I.N. -2480)	6359TN02 Diesel
(P.I.N. 2481-6000)	6359TN002, Diesel
(P.I.N. 6001-)	6059TN002, Diesel
Number of cylinders	6
Bore	106.5 mm (4.19 in.)
Stroke	110 mm (4.33 in.)
Displacement	5883 cm ³ (359 cu in.)
Horsepower	101 kW (135 hp)
Engine speeds	
Fast idle (no load)	2675—2725 rpm
Rated (under field load)	2500 rpm
Slow idle	800—900 rpm
Compression ratio	17.4 to 1

OPERATOR'S CAB

Type	SOUND-GARD® styled cab (with no ROPS) PERSONAL-POSTURE™ seat/deluxe suspension, heater, windshield wiper, and rear view mirror
Optional attachment	Air conditioner
Heater Capacity	5274 W (18,000 BTU)
Air conditioner	
Compressor make	Nippondenso
Capacity	6446 W (22,000 BTU)
Refrigerant	
9920; 9930 (P.I.N. -14000)	R-12
9930 (P.I.N. 14001-)	R134a
Refrigerant charge	
9920; 9930 (P.I.N. -14000)	2 kg (4-1/2 lb)
9930 (P.I.N. 14001-)	1.7 kg (3-3/4 lb)

NX1283,1005,C -19-10MAR94

METRIC BOLT AND CAP SCREW TORQUE VALUES

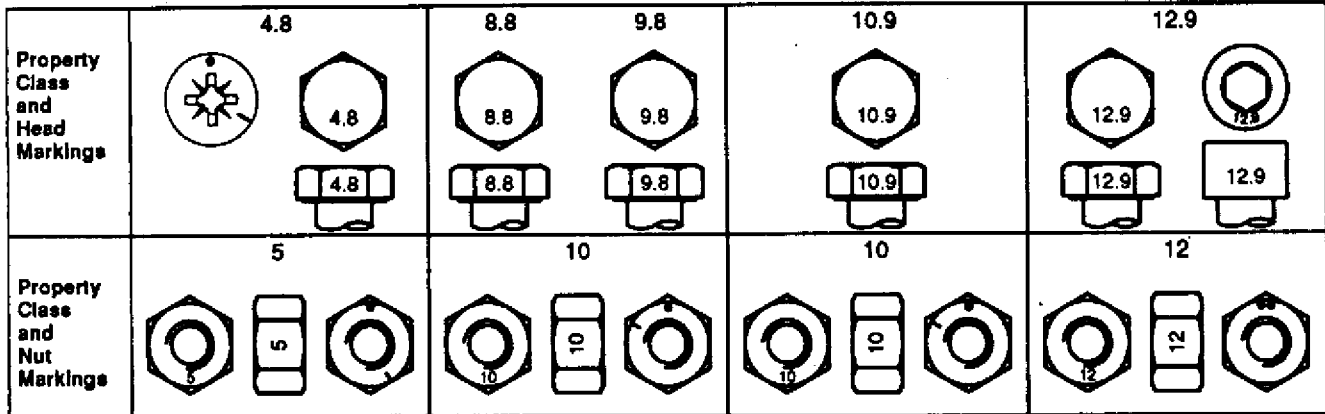

Size	Class 4.8				Class 8.8 or 9.8				Class 10.9				Class 12.9			
	Lubricated ^a		Dry ^a		Lubricated ^a		Dry ^a		Lubricated ^a		Dry ^a		Lubricated ^a		Dry ^a	
	N-m	lb-ft	N-m	lb-ft	N-m	lb-ft	N-m	lb-ft	N-m	lb-ft	N-m	lb-ft	N-m	lb-ft	N-m	lb-ft
M6	4.8	3.5	6	4.5	9	6.5	11	8.5	13	9.5	17	12	15	11.5	19	14.5
M8	12	8.5	15	11	22	16	28	20	32	24	40	30	37	28	47	35
M10	23	17	29	21	43	32	55	40	63	47	80	60	75	55	95	70
M12	40	29	50	37	75	55	95	70	110	80	140	105	130	95	165	120
M14	63	47	80	60	120	88	150	110	175	130	225	165	205	150	260	190
M16	100	73	125	92	190	140	240	175	275	200	350	225	320	240	400	300
M18	135	100	175	125	260	195	330	250	375	275	475	350	440	325	560	410
M20	190	140	240	180	375	275	475	350	530	400	675	500	625	460	800	580
M22	260	190	330	250	510	375	650	475	725	540	925	675	850	625	1075	800
M24	330	250	425	310	650	475	825	600	925	675	1150	850	1075	800	1350	1000
M27	490	360	625	450	950	700	1200	875	1350	1000	1700	1250	1600	1150	2000	1500
M30	675	490	850	625	1300	950	1650	1200	1850	1350	2300	1700	2150	1600	2700	2000
M33	900	675	1150	850	1750	1300	2200	1650	2500	1850	3150	2350	2900	2150	3700	2750
M36	1150	850	1450	1075	2250	1650	2850	2100	3200	2350	4050	3000	3750	2750	4750	3500

DO NOT use these values if a different torque value or tightening procedure is given for a specific application. Torque values listed are for general use only. Check tightness of fasteners periodically.

Shear bolts are designed to fail under predetermined loads. Always replace shear bolts with identical property class.

Fasteners should be replaced with the same or higher property class. If higher property class fasteners are used, these should only be tightened to the strength of the original.

^a "Lubricated" means coated with a lubricant such as engine oil, or fasteners with phosphate and oil coatings. "Dry" means plain or zinc plated without any lubrication.

Make sure fasteners threads are clean and that you properly start thread engagement. This will prevent them from failing when tightening.

Tighten plastic insert or crimped steel-type lock nuts to approximately 50 percent of the dry torque shown in the chart, applied to the nut, not to the bolt head. Tighten toothed or serrated-type lock nuts to the full torque value.

10
10
7
TS1163 -19-04MAR91

UNIFIED INCH BOLT AND CAP SCREW TORQUE VALUES

10
10
8

SAE Grade and Head Markings	1 or 2 ^b	5	5.1	5.2	8	8.2
SAE Grade and Nut Markings	2	5		8		

TS1162 -19-04/MAR91

Size	Grade 1				Grade 2 ^b				Grade 5, 5.1, or 5.2				Grade 8 or 8.2			
	Lubricated ^a		Dry ^a		Lubricated ^a		Dry ^a		Lubricated ^a		Dry ^a		Lubricated ^a		Dry ^a	
	N·m	lb-ft	N·m	lb-ft	N·m	lb-ft	N·m	lb-ft	N·m	lb-ft	N·m	lb-ft	N·m	lb-ft	N·m	lb-ft
1/4	3.7	2.8	4.7	3.5	6	4.5	7.5	5.5	9.5	7	12	9	13.5	10	17	12.5
5/16	7.7	5.5	10	7	12	9	15	11	20	15	25	18	28	21	35	26
3/8	14	10	17	13	22	16	27	20	35	26	44	33	50	36	63	46
7/16	22	16	28	20	35	26	44	32	55	41	70	52	80	58	100	75
1/2	33	25	42	31	53	39	67	50	85	63	110	80	120	90	150	115
9/16	48	36	60	45	75	56	95	70	125	90	155	115	175	130	225	160
5/8	67	50	85	62	105	78	135	100	170	125	215	160	215	160	300	225
3/4	120	87	150	110	190	140	240	175	300	225	375	280	425	310	550	400
7/8	190	140	240	175	190	140	240	175	490	360	625	450	700	500	875	650
1	290	210	360	270	290	210	360	270	725	540	925	675	1050	750	1300	975
1-1/8	400	300	510	375	400	300	510	375	900	675	1150	850	1450	1075	1850	1350
1-1/4	570	425	725	530	570	425	725	530	1300	950	1650	1200	2050	1500	2600	1950
1-3/8	750	550	950	700	750	550	950	700	1700	1250	2150	1550	2700	2000	3400	2550
1-1/2	1000	725	1250	925	990	725	1250	930	2250	1650	2850	2100	3600	2650	4550	3350

DO NOT use these values if a different torque value or tightening procedure is given for a specific application. Torque values listed are for general use only. Check tightness of fasteners periodically.

Fasteners should be replaced with the same or higher grade. If higher grade fasteners are used, these should only be tightened to the strength of the original.

Shear bolts are designed to fail under predetermined loads. Always replace shear bolts with identical grade.

Make sure fasteners threads are clean and that you properly start thread engagement. This will prevent them from failing when tightening.

Tighten plastic insert or crimped steel-type lock nuts to approximately 50 percent of the dry torque shown in the chart, applied to the nut, not to the bolt head. Tighten toothed or serrated-type lock nuts to the full torque value.

^a "Lubricated" means coated with a lubricant such as engine oil, or fasteners with phosphate and oil coatings. "Dry" means plain or zinc plated without any lubrication.

^b Grade 2 applies for hex cap screws (not hex bolts) up to 152 mm (6-in.) long. Grade 1 applies for hex cap screws over 152 mm (6-in.) long, and for all other types of bolts and screws of any length.

FLAT FACE O-RING SEAL FITTING TORQUE CHART

1. Inspect the fitting sealing surfaces. They must be free of dirt or defects.
2. Inspect the O-ring. It must be free of damage or defects.
3. Lubricate O-rings and install into groove using petroleum jelly to hold in place.
4. Push O-ring into the groove with plenty of petroleum jelly so O-ring is not displaced during assembly.
5. Index angle fittings and tighten by hand pressing joint together to insure O-ring remains in place.
6. Tighten fitting or nut to torque value shown on the chart per dash size stamped on the fitting. Do not allow hoses to twist when tightening fittings.

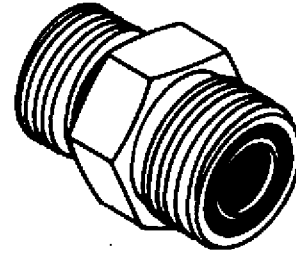

FLAT FACE O-RING SEAL FITTING TORQUE

Tube mm	Nominal O.D. (in.)	Dash Size	Thread Size in.	Swivel Nut Torque	
				N-m	(lb-ft)
6.35	0.250	-4	9/16-18	24	18
9.52	0.375	-6	11/16-16	30	22
12.70	0.500	-8	13/16-16	47	35
15.88	0.625	-10	1-14	75	55
19.05	0.750	-12	1 3/16-12	114	84
22.22	0.875	-14	1 3/16-12	114	84
25.40	1.000	-16	1 7/16-12	155	115
31.75	1.250	-20	1 11/16-12	193	142
38.10	1.500	-24	2-12	225	166

NOTE: Torque tolerance is +15 -20%.

910
-JUN-18OCT88
T6249AD

10
10
10

O-RING BOSS FITTING TORQUE CHART

STRAIGHT FITTING

1. Inspect O-ring boss seat for dirt or defects.
2. Lubricate O-ring with petroleum jelly. Place electrical tape over threads to protect O-ring. Slide O-ring over tape and into O-ring groove of fitting. Remove tape.
3. Tighten fitting to torque value shown on chart.

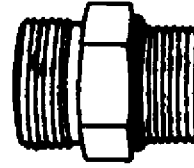

ANGLE FITTING

1. Back-off lock nut (A) and back-up washer (B) completely to head-end (C) of fitting.
2. Turn fitting into threaded boss until back-up washer (B) contacts face of boss.
3. Turn fitting head-end (C) counterclockwise to proper index (maximum of one turn).
4. Hold fitting head-end (C) with a wrench and tighten locknut (A) and back-up washer (B) to proper torque value.

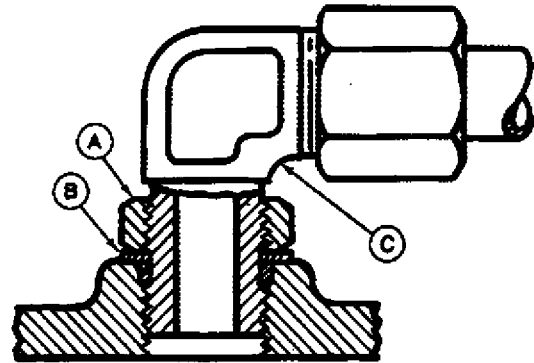

NOTE: Do not allow hoses to twist when tightening fittings.

TORQUE VALUE CHART

Thread Size	Torque N-m	(lb-ft)
3/8-24 UNF	8	(6)
7/16-20 UNF	12	(9)
1/2-20 UNF	16	(12)
9/16-18 UNF	24	(18)
3/4-16 UNF	46	(34)
7/8-14 UNF	62	(46)
1-1/16-12 UN	102	(75)
1-3/16-12 UN	122	(90)
1-5/16-12 UN	142	(105)
1-5/8-12 UN	190	(140)
1-7/8-12 UN	217	(160)

NOTE: Torque tolerance is $\pm 10\%$.

-JUN-18OCT88

T6249AE

-JUN-18OCT88

T6520AB

DIMENSIONS

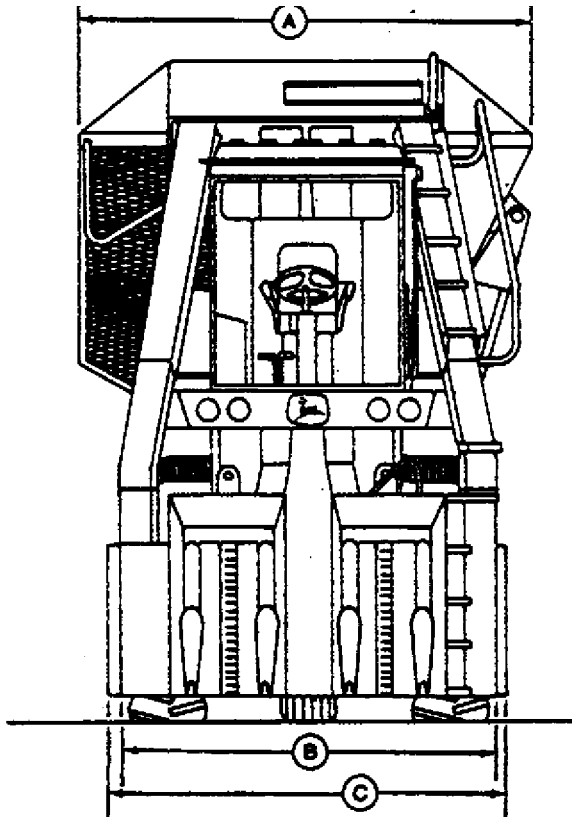

N36962 -JUN-27SEP88

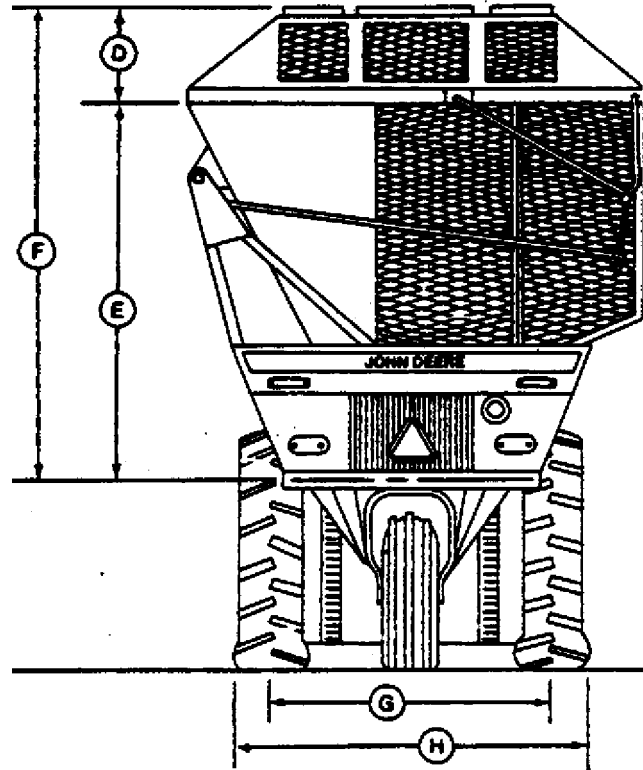

N36963 -JUN-27SEP88

- A—2997 mm (118 in.)
3073 mm (121 in.) (With extension)
- B—Without Wheel Shields
For 914 mm (36 in.) Rows-2337 mm (92 in.)
For 965 mm (38 in.) Rows-2388 mm (94 in.)
For 1016 mm (40 in.) Rows-2438 mm (96 in.)
- C—With Wheel Shields
For 914 mm (36 in.) Rows-2489 mm (98 in.)
For 965 mm (38 in.) Rows-2540 mm (100 in.)
For 1016 mm (40 in.) Rows-2591 mm (102 in.)
- D—584 mm (23 in.)
- E—2403 mm (94-5/8 in.)
- F—2990 mm (117-11/16 in.) (Standard)
3345 mm (131-11/16 in.) With 356 mm (14 in.)
Extension (9930 Only)
- G—2048 mm (80-5/8 in.) R1 or R3 Tires
2067 mm (81-3/8 in.) R2 Tires
- H—2464 mm (97 in.) R1 or R3 Tires
2534 mm (99-3/4 in.) R2 Tires

NX1283,1005,D -19-17SEP93

General Specifications/Dimensions

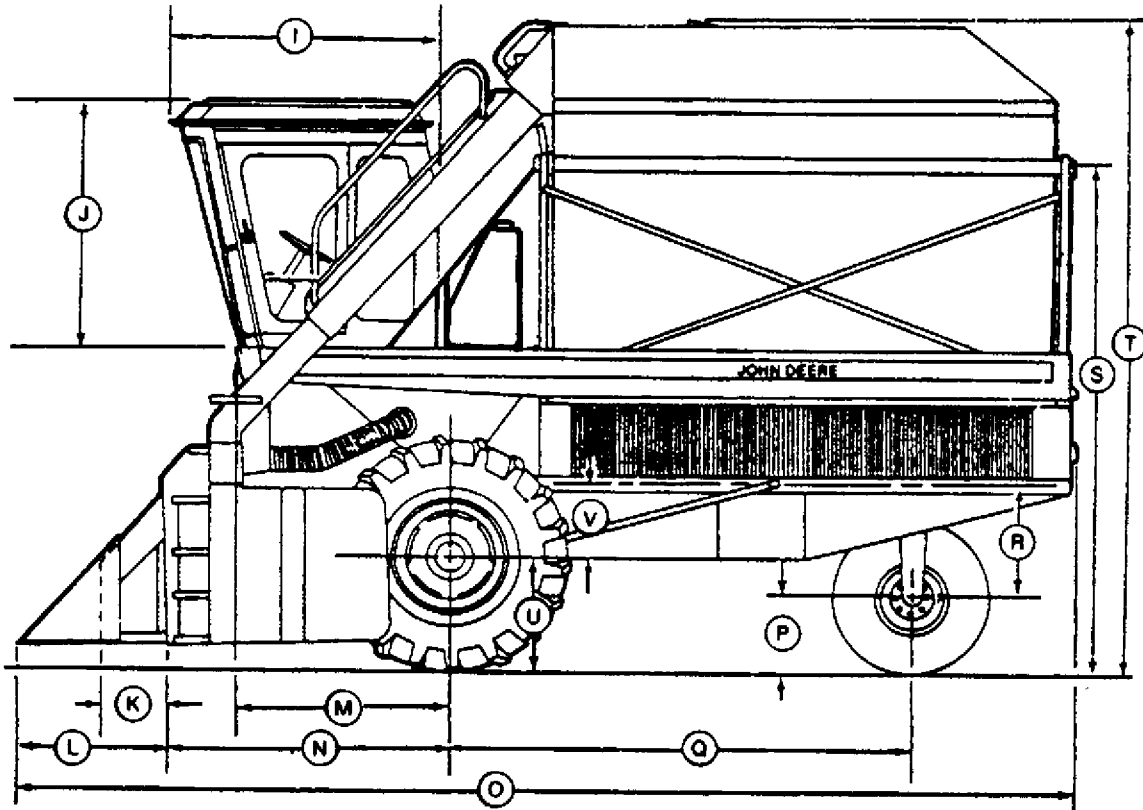

N36964A -JUN-24/FEB92

I—1740 mm (68-1/2 in.)	O—6769 mm (266-1/2 in.)	Q—2972 mm (117 in.)	U—716 mm (28-3/16 in.) (R1 and R3 Tires)
J—1638 mm (64-1/2 in.)	High Drum	R—721 mm (28-3/8 in.)	704 mm (27-11/16 in.) (R2 Tires)
K—376 mm (14-13/16 in.)	6779 mm (266-15/16 in.)	S—3175 mm (125 in.)	V—440 mm (17-5/16 in.)
L—935 mm (36-13/16 in.)	Low Drum	T—4128 mm (162-1/2 in.) (Standard)	
M—1461 mm (57-1/2 in.)	P—434 mm (17-1/16 in.)	4483 mm (176-1/2 in.)	
N—1921 mm (75-5/8 in.) High Drum	Clearance with Units Raised	With 356 mm (14 in.) Extension (9930 Only)	
1930 mm (76 in.) Low Drum			

(Specifications and design subject to change without notice.)

NX.N01.1005.AZ -19-09MAR92



Download the full PDF manual instantly.

Our customer service e-mail:

aservicemanualpdf@yahoo.com