

Product: EXCAVATOR

Model: 336D2 L EXCAVATOR YCF

Configuration: 336D2 & 336D2 L Excavators YCF00001-UP (MACHINE) POWERED BY C9 Engine

## Disassembly and Assembly

### 330D, 336D, 336D2, 340D and 340D2 Excavators and 336D MHPU Mobile Hydraulic Power Unit Machine Systems

Media Number -REN8648-30

Publication Date -01/03/2015

Date Updated -15/08/2018

i02732015

## Piston Pump (Hydraulic Fan) - Assemble

SMCS - 1387-016-QP; 5070-016-HFN

### Assembly Procedure

Table 1

Required Tools			
Tool	Part Number	Part Description	Qty
B	1P-1857	Retaining Ring Pliers	1
D	8T-5096	Dial Indicator Gp	1



Illustration 1

g01212915

1. Lower the temperature of bearing cup (49). Install bearing cup (49).

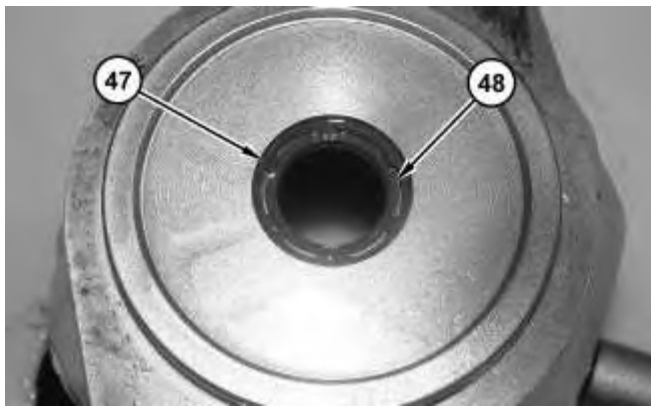

Illustration 2

g01212913

2. Install lip seal (48).
3. Use Tooling (B) in order to install retaining ring (47).

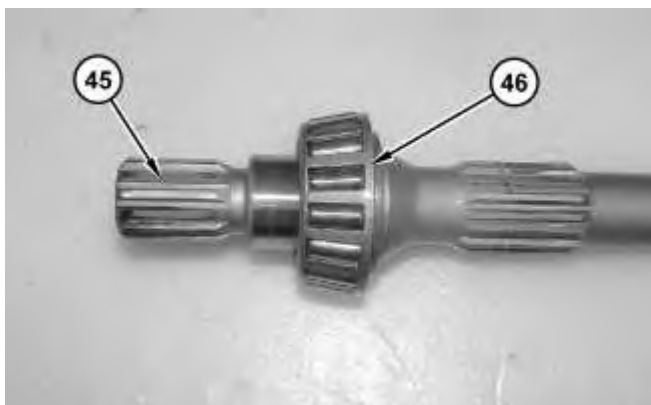

Illustration 3

g01213404

4. Raise the temperature of bearing cone (46).
5. Install bearing cone (46) onto shaft (45).

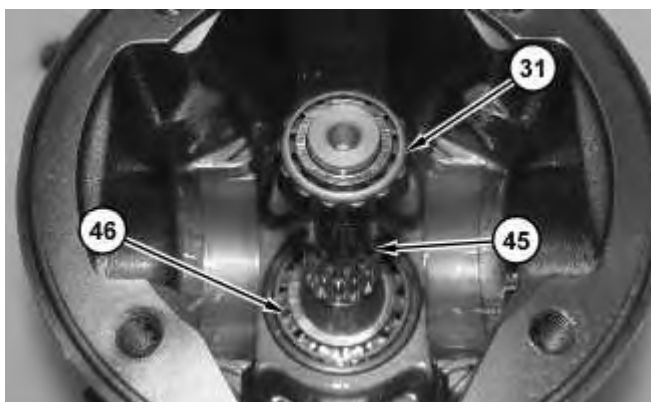

Illustration 4

g01213405

6. Install bearing cone (46), shaft (45), and bearing cone (31).

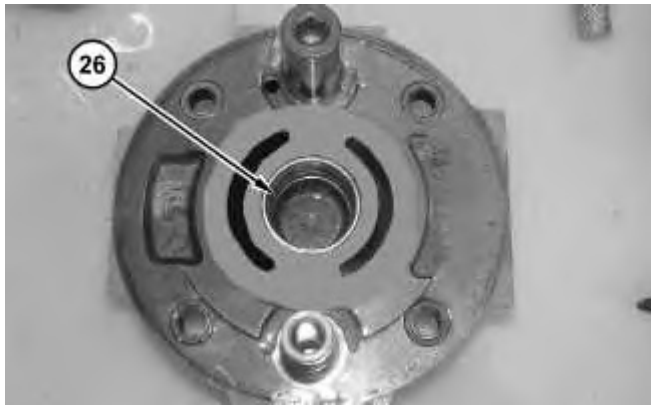

Illustration 5

g01213407

7. Lower the temperature of bearing cone (26). Install bearing cone (26).

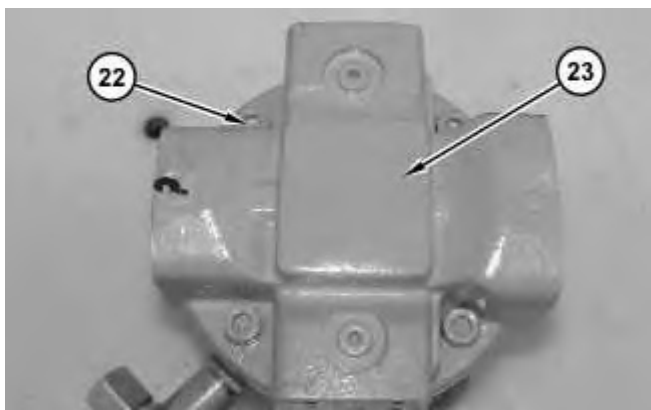

Illustration 6

g01212900

8. Position head (23) onto the housing.
9. Install bolts (22).



Illustration 7

g01213409

10. Use Tooling (D) in order to determine the end play of shaft (45).
-

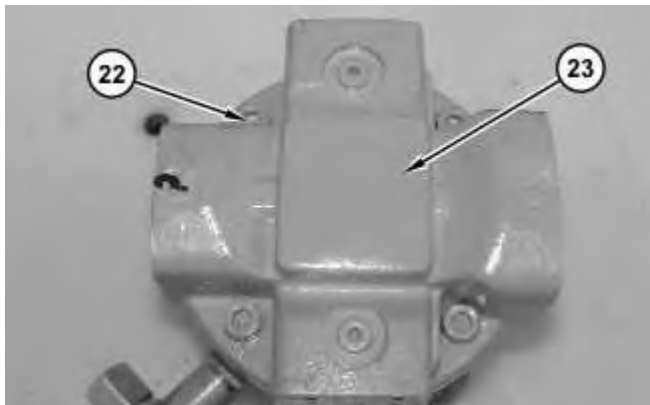

Illustration 8

g01212900

11. Remove bolts (22) and head (23).

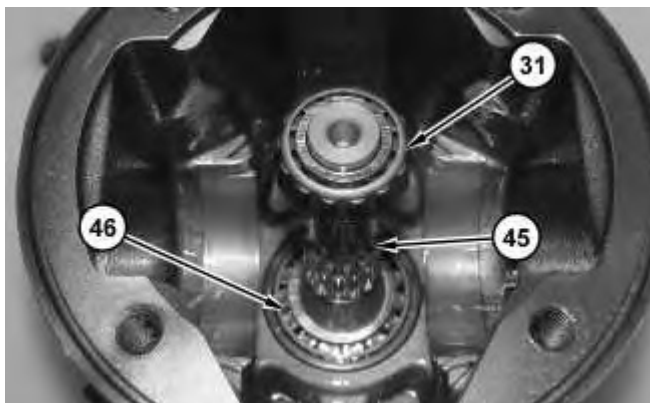

Illustration 9

g01213405

12. Remove bearing cone (31).

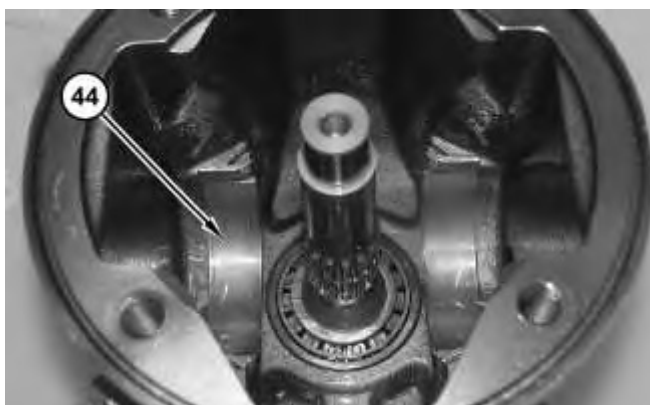

Illustration 10

g01213433

13. Install bearings (44).

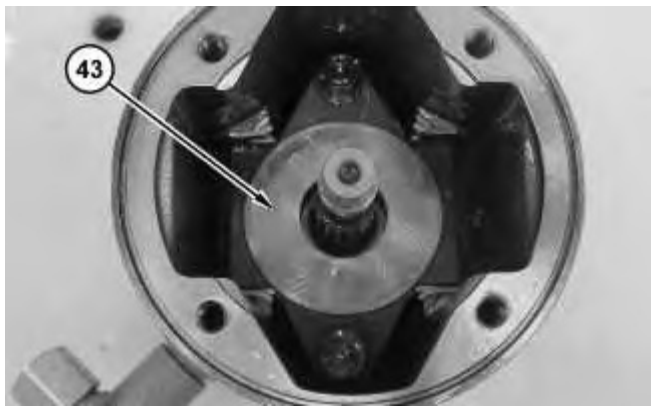

Illustration 11

g01212910

14. Install swashplate (43).

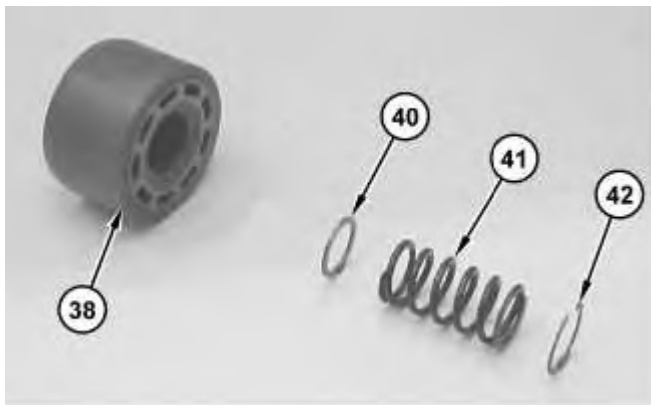

Illustration 12

g01373818

15. Install shim (40), spring (41), and shim (42) to barrel (38).

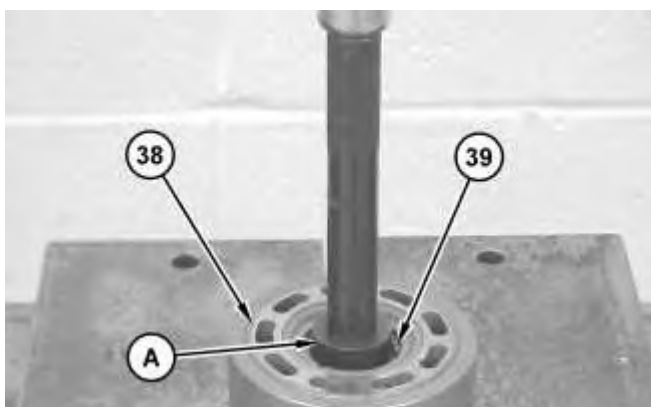

Illustration 13

g01212908



**WARNING**

**Improper assembly of parts that are spring loaded can cause bodily injury.**

**To prevent possible injury, follow the established assembly procedure and wear protective equipment.**

---

16. Use Tooling (A), Tooling (B), and a suitable press in order to install retaining ring (39) into barrel (38).

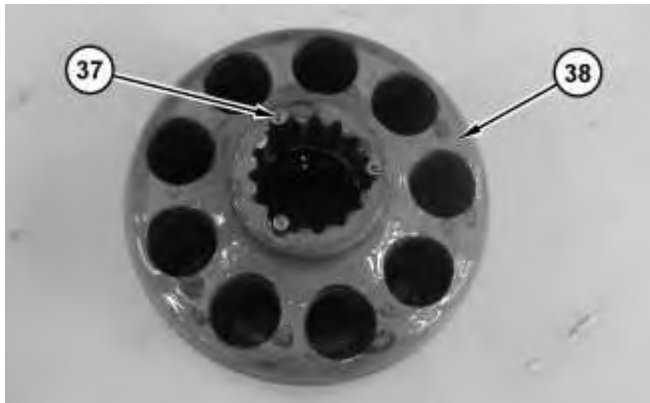

Illustration 14

g01212907

17. Install pins (37) into barrel (38).

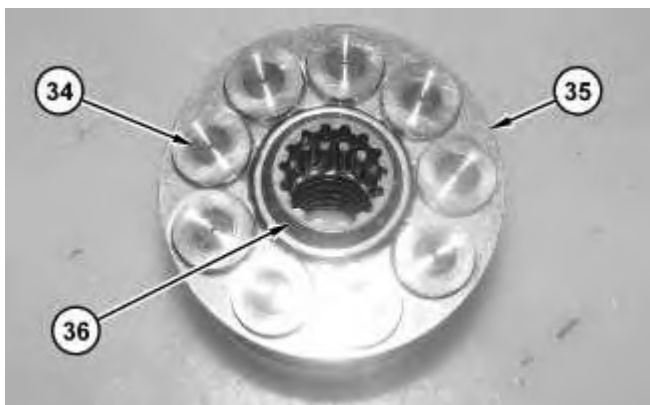

Illustration 15

g01212906

18. Install bearing (36), retainer (35), and pistons (34).
-

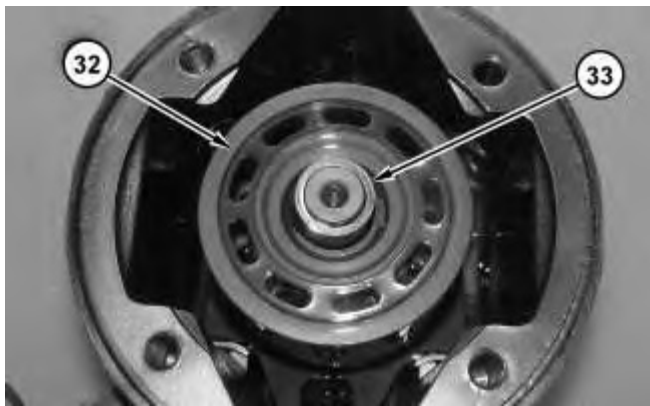

Illustration 16

g01212905

19. Install rotating group (32) and shim (33).

**Note:** Shim thickness was determined on Step 9.

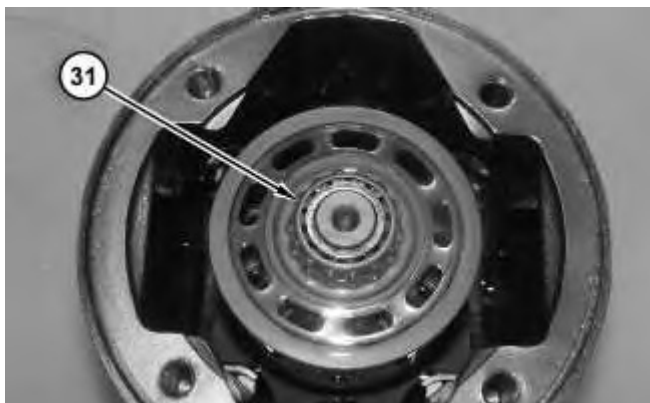

Illustration 17

g01212904

20. Install bearing cone (31).

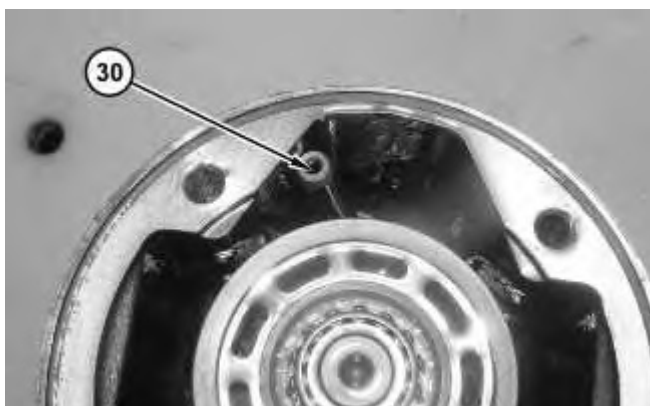

Illustration 18

g01212903

21. Install piston (30).



**Download the full PDF manual instantly.**

**Our customer service e-mail:**

**[aservicemanualpdf@yahoo.com](mailto:aservicemanualpdf@yahoo.com)**